



An update on systematics at higher ILC energies

I. Smiljanić, T. Jovin, I. Božović–Jelisavčić, M. Pandurović



HEA FPOVA VITCX



I. Smiljanić, FCAL Workshop, Krakow, 12-13 April 2010

- Forward region of the ILC, Luminosity Calorimeter
- Luminosity measurement: physics, systematics
- Event selection: Asymmetric cuts + relative energy cut
- Bias of energy scale
- Luminosity vs. E resolution
- Conclusion



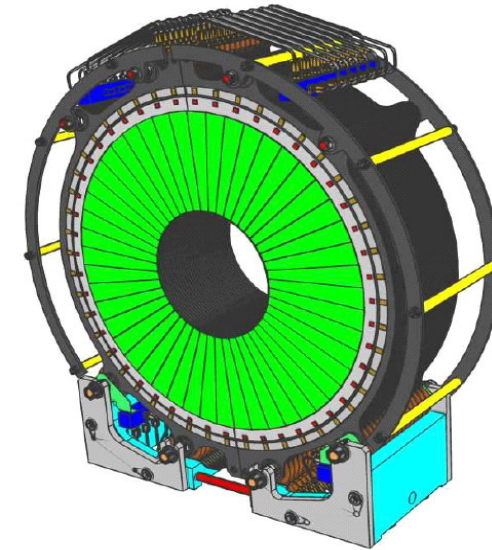
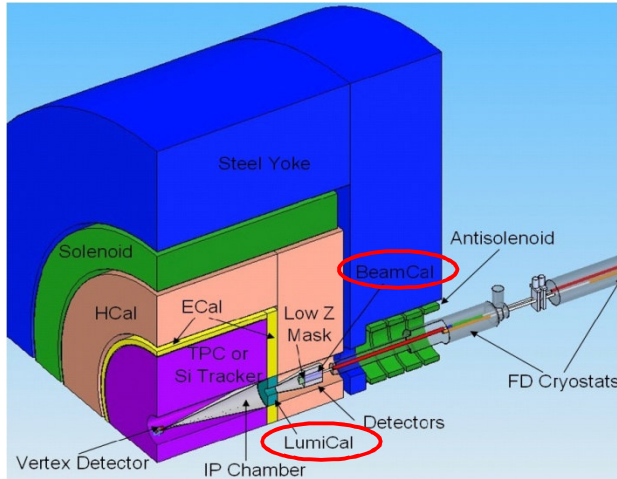

Silicon sensor half plane

Distance from IP [m]	2.5
Geometrical aperture [mrad]	[31-78]
Fiducial volume [mrad]	[38-69]
Number of layers	30 W/Si
Moliere radius [cm]	1.5
Sensor azimuthal/radial divisions	48/64
Resolution in polar angle [mrad]	$(2.2 \pm 0.02) \cdot 10^{-2}$
Energy resolution [GeV^{1/2}]	0.21

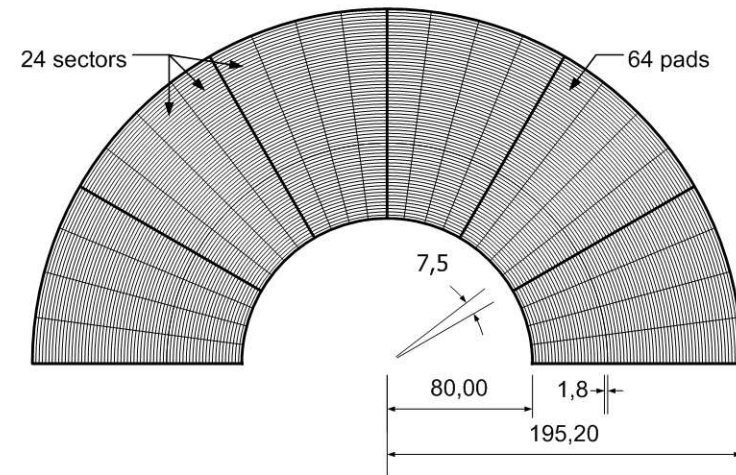

HEP & XRD & VIT(X)





Luminosity measurement



old geometry, physical volume (25-87 mrad) →

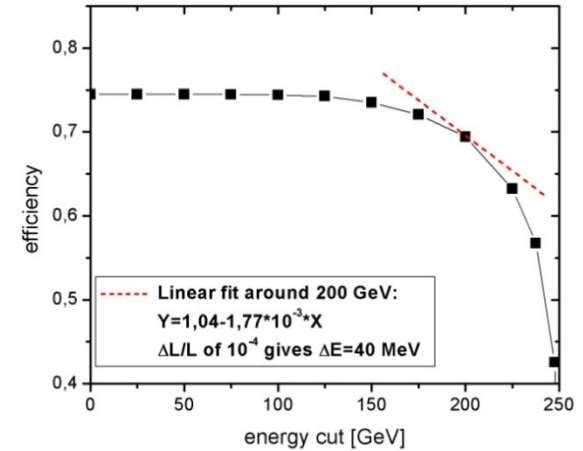

present geometry, fiducial volume (38-69 mrad) ↓

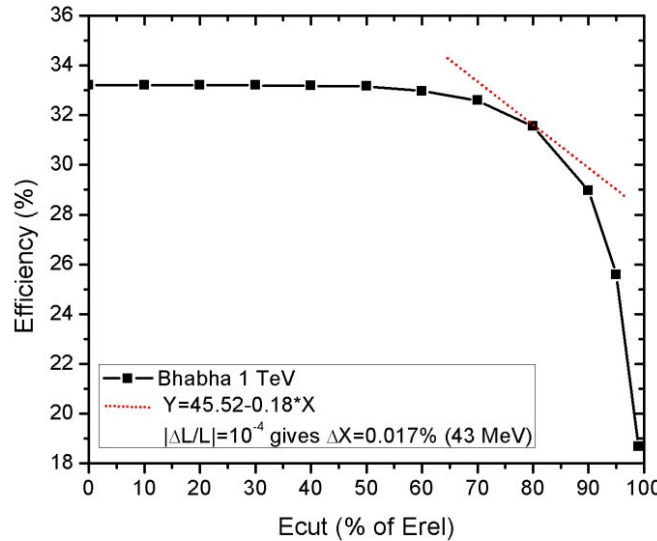
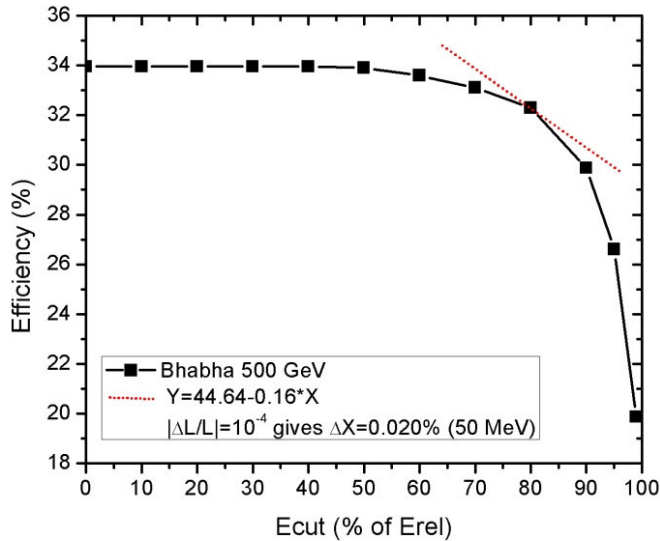

According to the declared luminosity of $2 \times 10^{34} \text{ cm}^2 \text{ s}^{-1}$, there should be about 10^9 Bhabha events per year – should we really worry about the efficiency?



HEP FROM A VIT(A)



I. Smiljanić, FCAL Workshop, Krakow, 12-13 April 2010

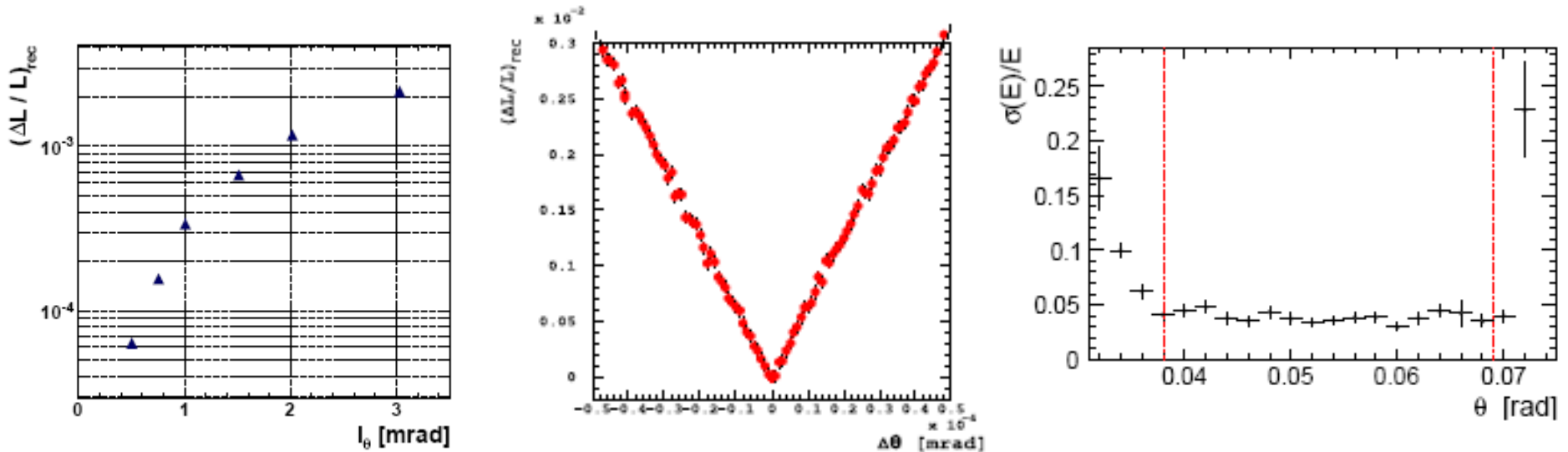

Shower develops under a non-zero angle with respect to the probing geometry \Leftrightarrow bias in luminosity measurement

The polar resolution of LumiCal is $\sigma_\theta = (2.2 \pm 0.01) \times 10^{-2}$ mrad (θ_{res} on the plot). For this value of polar resolution, $|\Delta L/L| = 1.6 \times 10^{-4}$. Smearing the value of polar angle around that value shows that $|\Delta L/L|$ stays at the 10^{-4} level even if we have a 100% uncertainty of σ_θ .

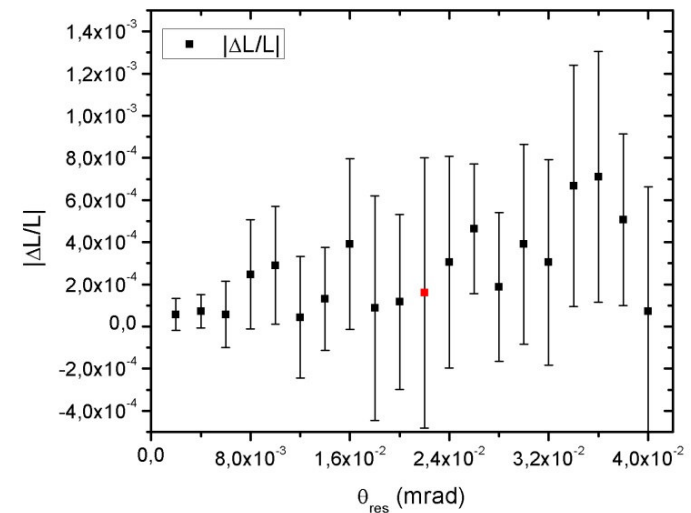

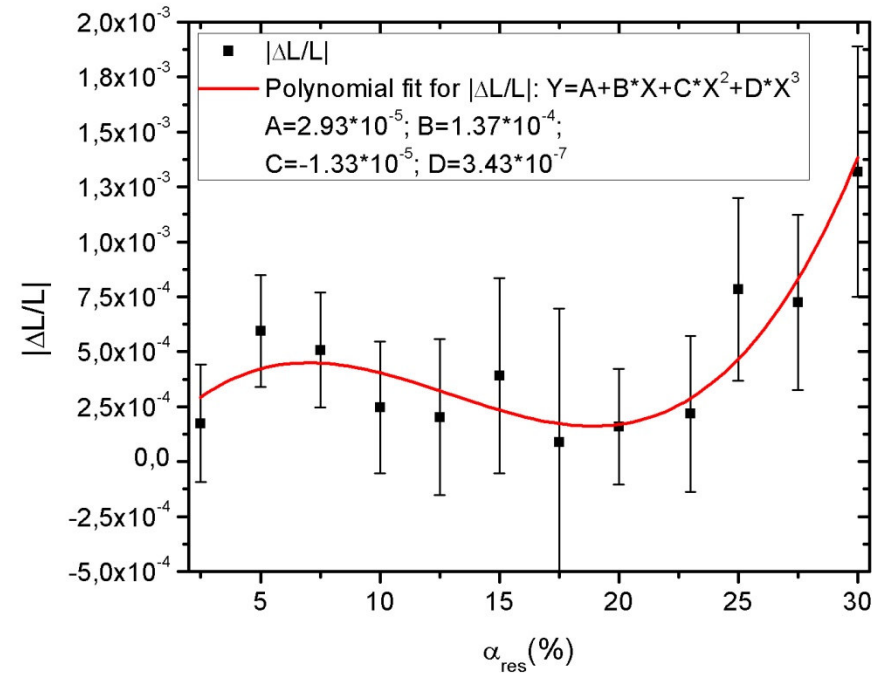
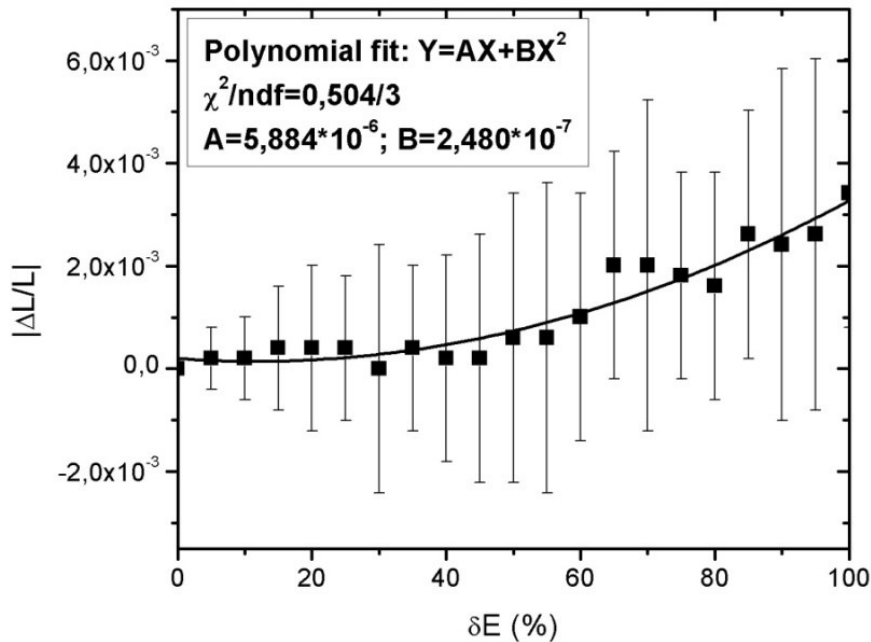

old geometry, physical volume (25-87 mrad): for declared energy resolution of $\alpha_{res}(\delta E) = 21\%$, $|\Delta L/L| = 2.32*10^{-4}$.

new geometry, fiducial volume (38-69 mrad): for declared energy resolution of $\alpha_{res} = 21\%$, $|\Delta L/L| = 2.18*10^{-4}$.





Other sources of systematics – 2- γ background



Multiperipheral

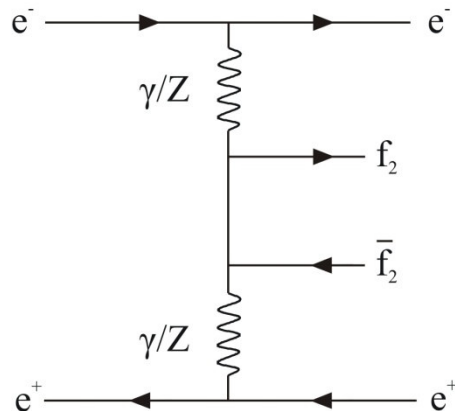

High x-sec ~ 10 s nb, spectators close to the beam pipe – less than 1% of spectators in the LumiCal

Problem with difference between BDK and WHIZARD is solved – it is possible to tune WHIZARD to reproduce BDK or experimental results (for eecc)...

B/S ratio saturates within the same order of magnitude at ILC energies - $B/S = 2.3 \cdot 10^{-3}$ at 500 GeV and $B/S = 5.2 \cdot 10^{-3}$ at 1 TeV

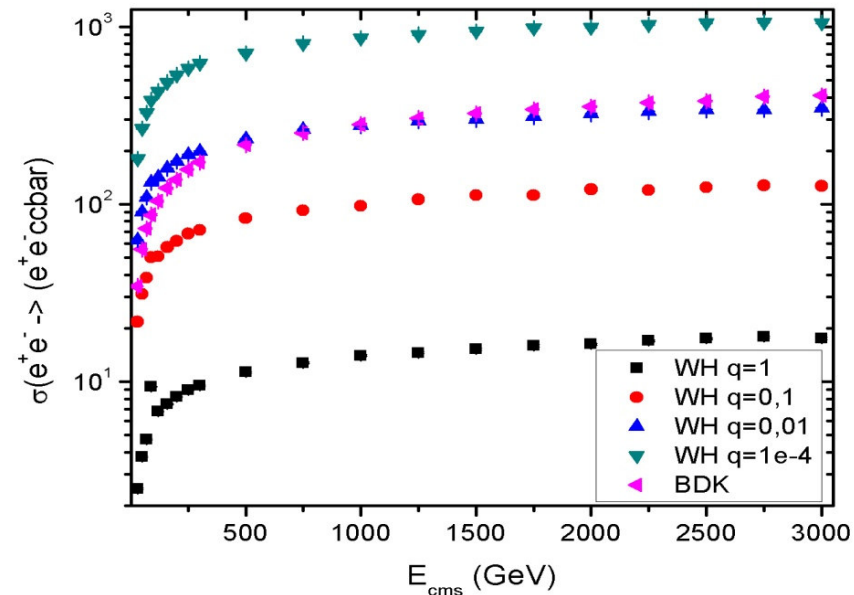
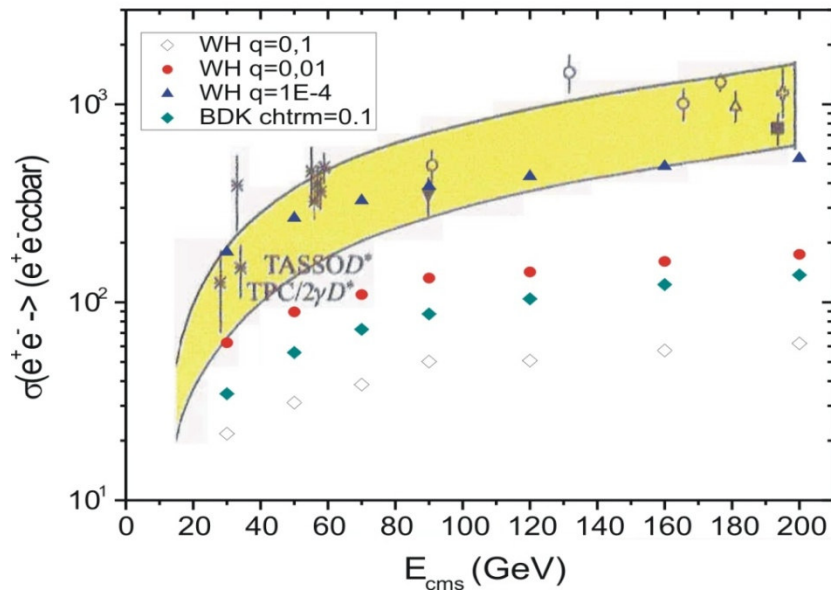

HEA & XODAP VIT(X)



I. Smiljanić, FCAL Workshop, Krakow, 12-13 April 2010

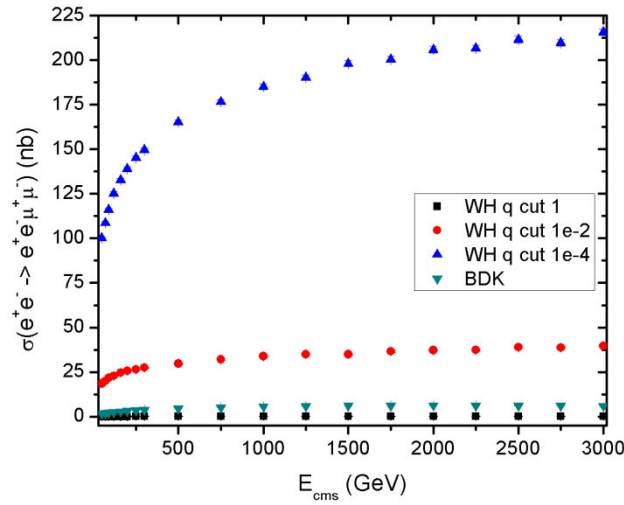

... but what to do with eell?

Background hits on the front plane before and after selection applied

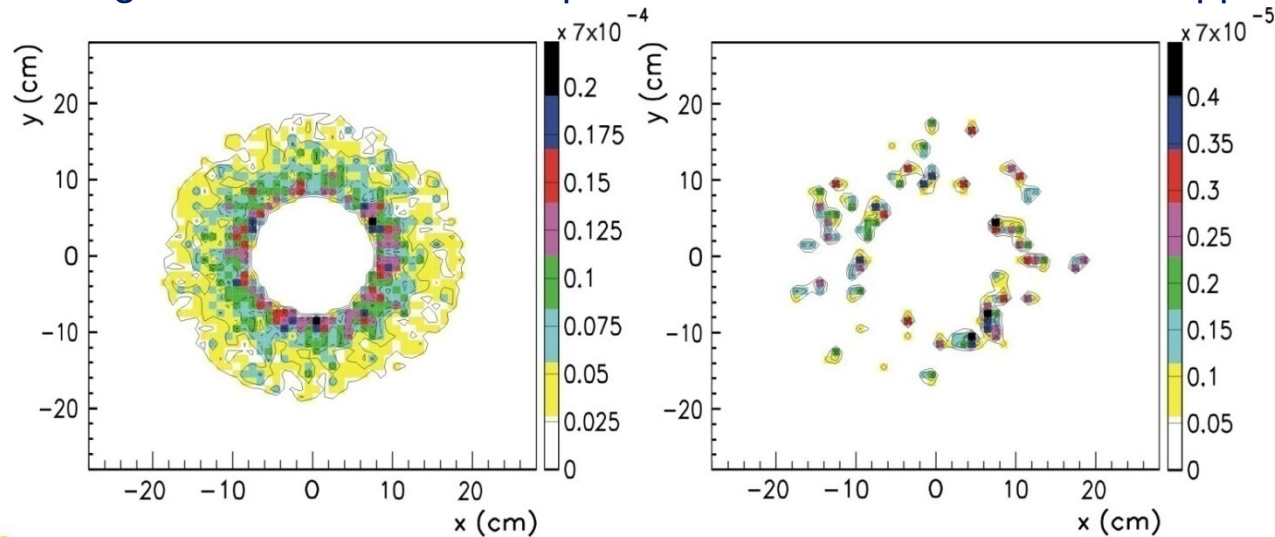



More systematics – space charge effects



Beam-beam interactions

- Modification of initial state: **Beamstrahlung**
 $\Rightarrow \sqrt{s}' \leq \sqrt{s}, \Delta\theta_{ini} \neq 0, E_{elec} \neq E_{posit}$
- Modification of final state: **Electromagnetic deflection** \Rightarrow Bhabha angle reduction ($\sim 10^{-2}$ mrad) + small energy losses

Total BHabha Suppression Effect (BHSE)
 $\sim 1.5\%$

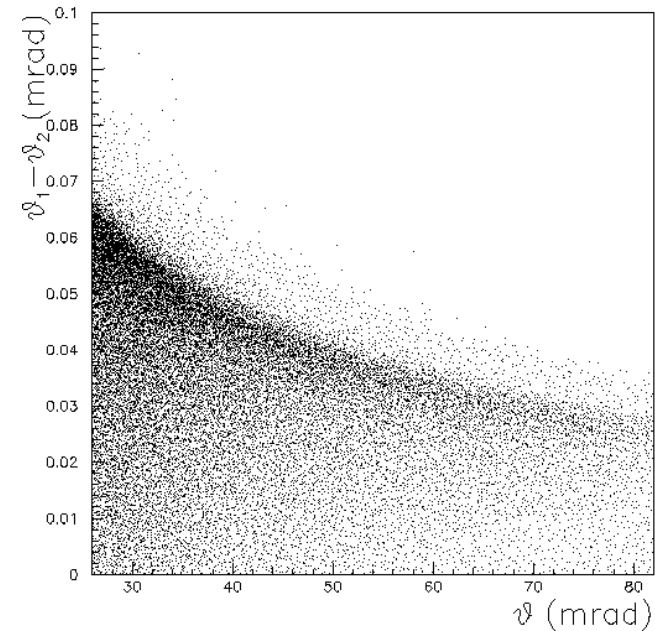

HEP & XOV A VIT (X



I. Smiljanić, FCAL Workshop, Krakow, 12-13 April 2010

Data-driven method from reconstructed luminosity spectrum by measuring angles in the LumiCal

$$\frac{\sqrt{s'}}{\sqrt{s}} \simeq \sqrt{1 - 2 \frac{\sin(\theta_1 + \theta_2)}{\sin(\theta_1 + \theta_2) - \sin\theta_1 - \sin\theta_2}}$$

Dominant effect comes from beamstrahlung

- ➔ BHSE from BS can be exp. measured and treated as a bias
- ➔ However, to provide $\Delta(\text{BHSE}) \sim 0.4\%$ (0.1%) beam parameters σ_x and σ_z have to be known within 20% (5%).

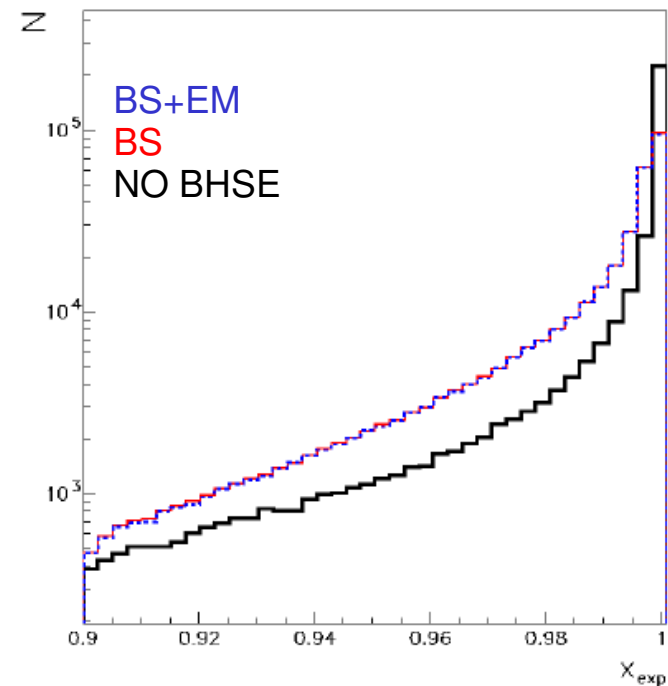

SUMMARY ON SYSTEMATICS

- Test beam studies are needed to determine experimental uncertainties of effects that should be taken as corrections (i.e. bias in polar angle).
- Precision determination of Bhabha energy and understanding of detector energy resolution is necessary due to the applied selection.
- NLO calculations at ILC energies are needed both for Bhabha and background processes.
- **Dominant effects come from beam-beam interaction (BHSE) and 2- γ processes. Both can be corrected for. In BHSE case the correction is large and require beam parameter control at 20% level or better (BS component), while uncertainty in physics background comes from the error on x-section.**

Bunch width variation for ± 100 nm around nominal value $\sigma_x = 655$ nm

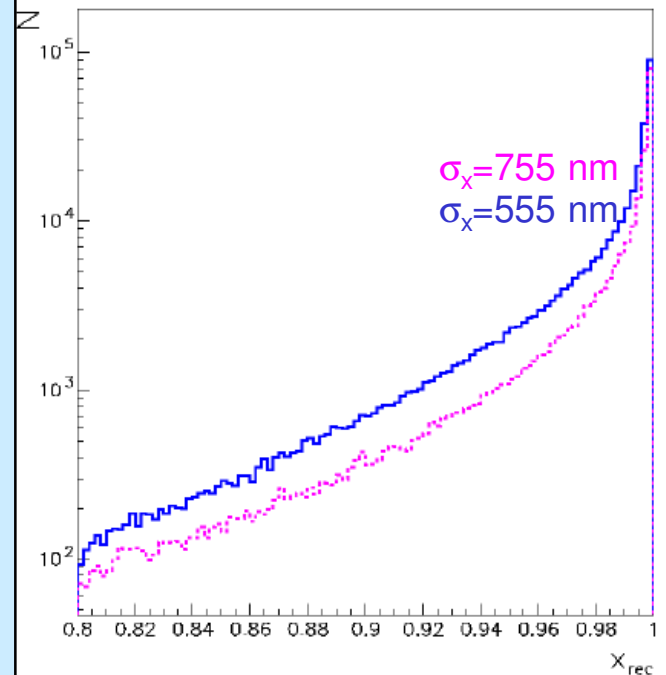

**TOTAL SYSTEMATICS
at 500 GeV**

	Value	Uncertainty of the value	$\Delta L/L$
x-sec_{Bhabha} [nb]	2.1	$5.4 \cdot 10^{-4}^{**}$	$5.4 \cdot 10^{-4}$
σ_{θ} [mrad]	$2.2 \cdot 10^{-2}$	$2.2 \cdot 10^{-2}^*$	$1.6 \cdot 10^{-4}$
$\Delta\theta$ [mrad]	$3.2 \cdot 10^{-3}$	$1.6 \cdot 10^{-4}^*$	$1.6 \cdot 10^{-4}$
α_{res} [GeV^{-1/2}]	0.21	1.5%	$1.0 \cdot 10^{-4}$
E_{Bhabha} [GeV]	≥ 200	$4.0 \cdot 10^{-2}$	$1.0 \cdot 10^{-4}$
B/S	$2.3 \cdot 10^{-3}$	$2.3 \cdot 10^{-3}^*$	$2.3 \cdot 10^{-3}$
BHSE	1.51%	0.10%***	$1.5 \cdot 10^{-3}$
Σ			$2.8 \cdot 10^{-3}$

* marks upper limits.

** Uncertainty of the theoretical cross-section for Bhabha at LEP energies [OPAL, G. Abiendi et al., Eur. Phys. J C14(2000)373].

*** 5% control of buch x and z sizes.



TOTAL SYSTEMATICS at 1 TeV

	Value	Uncertainty of the value	$\Delta L/L$
x-sec_{Bhabha} [nb]	1.1	$5.4 \cdot 10^{-4}^{**}$	$5.4 \cdot 10^{-4}$
σ_θ [mrad]	$2.2 \cdot 10^{-2}$	$2.2 \cdot 10^{-2}^*$	$1.6 \cdot 10^{-4}$
$\Delta\theta$ [mrad]	$3.2 \cdot 10^{-3}$	$1.6 \cdot 10^{-4}^*$	$1.6 \cdot 10^{-4}$
α_{res} [GeV^{-1/2}]	0.21	To be established	To be established
E_{Bhabha} [GeV]	≥ 400	$4.0 \cdot 10^{-2}$	$1.0 \cdot 10^{-4}$
B/S	$5.2 \cdot 10^{-3}$	$5.2 \cdot 10^{-3}^*$	$5.2 \cdot 10^{-3}$
BHSE	1.51%	0.10% ^{***}	$1.5 \cdot 10^{-3}$
Σ			To be established

* marks upper limits.

** Uncertainty of the theoretical cross-section for Bhabha at LEP energies [OPAL, G. Abiendi et al., Eur. Phys. J C14(2000)373].

*** 5% control of buch x and z sizes.



- It has been proven through simulation that it is possible to design luminometer at ILC capable of precision reconstruction of Bhabha energy and polar angle.
- Numerous systematic effects are present and understood (again) at the level of simulation. They amount to $2.8 \cdot 10^{-3}$ **systematic uncertainty in luminosity at the upper limit**, with the statistical error on luminosity less than 10^{-3} needed for integrated annual luminosity at high energies.
- Most of systematic effects can be taken as corrections once their experimental (test-beam) or theoretical uncertainties are known.
- **The largest contribution to the relative error on luminosity comes from collective (beam-beam) effects and physics background.** According to the present knowledge, beam-beam effects can not be reduced below 10^{-3} (even if bunch size is controlled at 5% level). However, it doesn't relax the need for detector precision.



- Sensitivity of the luminosity measurement to changes of the detector fiducial volume implies **importance of mechanics and position control** of the LumiCal (inner radius, various radial displacements, F-B relative positions, etc.). It is needed to **quantify impact of these effects on luminosity measurements** within the current detector geometry, as well as **to prove in situ mechanical control**.
- **Test-beam studies are needed** to understand experimental uncertainties of some effects (i.e. realistic calibration procedure).
- **Space charge effects** introduce error in luminosity measurement of order of 10^{-3} . They **have to be studied** in more details with respect to changes in geometry and at all ILC energies*.
- Finally, for the reason of completeness, **theoretical** uncertainties at the NLO level **are needed** for Bhabha and background processes at ILC energies*.
- **Final choice of shape and material of the beam-pipe has to be simulated** to estimate impact of pre-showering on luminosity measurement. For parallel vs. conical beryllium pipe the effect is estimated to be $O(10^{-4})$.

* the same is true for CLIC

